

# LDM Series Modulated Lasers

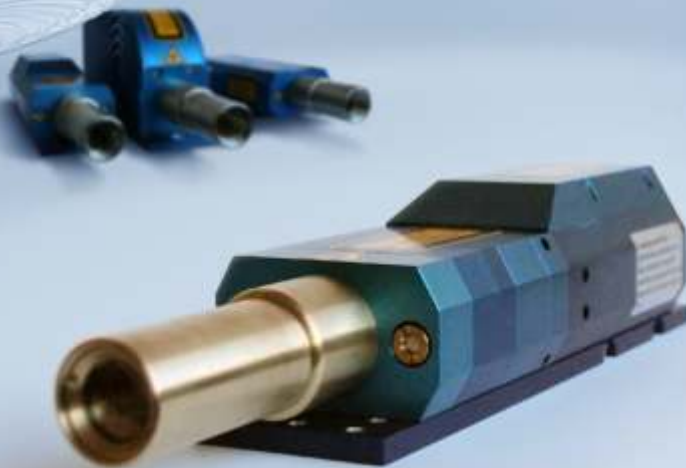

150 / 500 - Modulated Lasers  
with >150 / >500MHz Digital  
Modulation Speed



	Blue- /Greenphoton® 150/500	Redphoton® 150/500
Wavelengths & Powers (other wavelengths and powers on request)	<b>Single-Mode (SM):</b> 375nm / 20mW 395nm / 120mW 405nm / 55mW, 120mW 415nm / 120mW 425nm / 120mW 445nm / 50mW, 100mW 457nm / 100mW 460nm / 100mW 473nm / 20mW, 80mW 488nm / 20mW, 60mW, 80mW 515nm / 25mW <b>Multi-Mode (MM):</b> 375nm / 200mW (M <sub>r</sub> = 5...6) 405nm / 400mW (M <sub>r</sub> = 5...6) 445nm / 500mW (M <sub>r</sub> = 2...3)	<b>Single-Mode (SM):</b> 635nm / 5mW 637nm / 150mW 639nm / 40mW, 100mW 643nm / 150mW 658nm / 130mW 670nm / 15mW 685nm / 35mW 785nm / 120mW 808nm / 200mW 830nm / 200mW 852nm / 150mW 980nm / 150mW 1016nm / 100mW 1060nm / 100mW <b>Multi-Mode (MM):</b> 638nm / 250mW 670nm / 500mW 808nm / 1000mW (others on request)
Beam diameter (other diameters on request)	1.25mm (1/e <sup>2</sup> ) +/- 0.25mm 3 mm (1/e <sup>2</sup> ) +/- 0.3mm	1.25mm (1/e <sup>2</sup> ) +/- 0.25mm 3 mm (1/e <sup>2</sup> ) +/- 0.3mm
Beam quality M <sup>2</sup>	< 1.2 (SM) < 6 (MM)	< 1.2 (SM) < 6 (MM)
Astigmatism (corrected)	< 0.2*ZR	< 0.2*ZR
Beam ellipticity	< 1.1:1 (SM)	< 1.1:1 (SM)
Polarisation	> 100:1 vertical	> 100:1 vertical
Power stability	< 0.5% / h	< 0.5% / h
Noise 0Hz-100MHz	< 0.5% peak <-> peak (CW)	< 0.5% peak <-> peak (CW)
Modulation speed	Analog: 1MHz Digital: >150MHz (150 Mod.) Digital: >500MHz (500 Mod.)	
Modulation input signals	Analog: 0...5V -> 0...100% Digital: TTL, PECL LV-TTL or LVDS on request	
Rise and fall time	< 1ns>	
Extinction ratio	250 : 1	
Supply voltage	24 VDC, 2 Amp.	
Features	Safety-Interlock RS-232 interface	
Options	LDM.COL - collimator objective LDM.FOC - customized focussing objective LDM.FASVXXX - fibre coupling unit LDM.AAC - Automatic Aging Compensation LDM.24VPSU - worldwide power supply unit LDM.MON - high-speed light monitoring	

**MORE**

LDM□□□□.□□□.□□□□  
Wavelength in nm Power in mW Model 150 or 500 (in MHz)

### 150/500 Controller

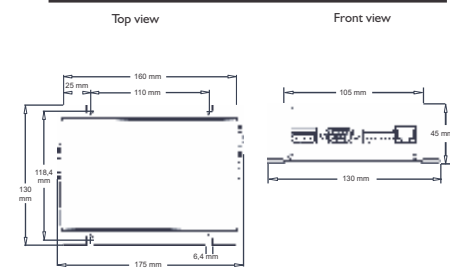

### 150/500 Laserhead

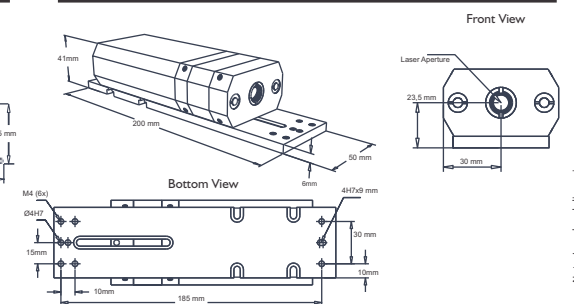

Note: Laserhead dimensions may vary



Blue- /Greenphoton® TA

Redphoton® 150/500

Wavelengths & Powers (other wavelengths and powers on request)	<p><b>Single-Mode (SM):</b> 375nm / 20mW 395nm / 120mW 405nm / 55mW, 120mW 415nm / 120mW 425nm / 120mW 445nm / 50mW, 100mW 457nm / 100mW 460nm / 100mW 473nm / 20mW, 80mW 488nm / 20mW, 60mW, 80mW 515nm / 25mW</p> <p><b>Multi-Mode (MM):</b> 375nm / 200mW (M<sup>2</sup> = 5...6) 405nm / 400mW (M<sup>2</sup> = 5...6) 445nm / 500mW (M<sup>2</sup> = 2...3)</p>	<p><b>Single-Mode (SM):</b> 635nm / 5mW 637nm / 150mW 639nm / 40mW, 100mW 643nm / 150mW 658nm / 130mW 670nm / 15mW 685nm / 35mW 785nm / 120mW 808nm / 200mW 830nm / 200mW 852nm / 150mW 980nm / 150mW</p> <p>1016nm / 100mW 1060nm / 100mW</p> <p><b>Multi-Mode (MM):</b> 638nm / 250mW (others on request)</p>
Beam diameter (other diameters on request)	1.25mm (1/e <sup>2</sup> ) +/- 0.25mm 3 mm (1/e <sup>2</sup> ) +/- 0.3mm	1.25mm (1/e <sup>2</sup> ) +/- 0.25mm 3 mm (1/e <sup>2</sup> ) +/- 0.3mm
Beam quality M <sup>2</sup>	<1.2 (SM) <6 (MM)	<1.2 (SM) <6 (MM)
Astigmatism (corrected)	<0.2*ZR	<0.2*ZR
Beam ellipticity	<1.1:1 (SM)	<1.1:1 (SM)
Polarisation	>100:1 vertical	>100:1 vertical
Power stability	<0.5% / h	<0.5% / h
Noise 0Hz-100MHz	<0.5% peak<>peak (CW)	<0.5% peak<>peak (CW)
Modulation speed	Analog: up to 15MHz @ -3dB Digital: >150MHz	
Modulation input signals	Analog: 0...1V / 50 Ohm (15MHz) or Analog: 0...5V / 10 kOhm (>5MHz) Digital: 0...1V / 50 Ohm with prog. Trigger-Level (>150MHz) or Digital: 0...5V / 200 Ohm with prog. Trigger-Level (>100MHz)	
Rise and fall time	Analog: <25ns Digital: <1ns	
Modulation depth	> 2.500.000:1	
Supply voltage	24VDC, 2 Amp.	
Features	Safety- Interlock RS-232 Interface	
Options	LDM.COL - collimator objective LDM.FOC - customized focussing objective LDM.FASYXXX - fibre coupling unit LDM.AAC - Automatic Aging Compensation LDM.24VPSU - worldwide power supply unit LDM.MON - high-speed light monitoring	

Blue- /Greenphoton® DC180

Redphoton® DC180

Wavelengths & Powers (other wavelengths and powers on request)	<p><b>Single-Mode (SM):</b> 375nm / 20mW 395nm / 120mW 405nm / 55mW, 120mW 415nm / 120mW 425nm / 120mW 445nm / 50mW, 100mW 457nm / 100mW 460nm / 100mW 473nm / 20mW, 80mW 488nm / 20mW, 60mW, 80mW 515nm / 25mW</p> <p><b>Multi-Mode (MM):</b> 375nm / 200mW (M<sup>2</sup> = 5...6) 405nm / 400mW (M<sup>2</sup> = 5...6) 445nm / 500mW (M<sup>2</sup> = 2...3)</p>	<p><b>Single-Mode (SM):</b> 635nm / 5mW 637nm / 150mW 639nm / 40mW, 100mW 643nm / 150mW 658nm / 130mW 670nm / 15mW 685nm / 35mW 785nm / 120mW 808nm / 200mW 830nm / 200mW 852nm / 150mW 980nm / 150mW</p> <p>1016nm / 100mW 1060nm / 100mW</p> <p><b>Multi-Mode (MM):</b> 638nm / 250mW (others on request)</p>
Beam diameter (other diameters on request)	1.25mm (1/e <sup>2</sup> ) +/- 0.25mm 3 mm (1/e <sup>2</sup> ) +/- 0.3mm	1.25mm (1/e <sup>2</sup> ) +/- 0.25mm 3 mm (1/e <sup>2</sup> ) +/- 0.3mm
Beam quality M <sup>2</sup>	<1.2 (SM) <6 (MM)	<1.2 (SM) <6 (MM)
Astigmatism (corrected)	<0.2*ZR	<0.2*ZR
Beam ellipticity	<1.1:1 (SM)	<1.1:1 (SM)
Polarisation	>100:1 vertical	>100:1 vertical
Power stability	<0.5% / h	<0.5% / h
Noise 0Hz-100MHz	<0.5% peak<>peak (CW)	<0.5% peak<>peak (CW)
Modulation speed	2x Analog: 1MHz 2x Digital >180MHz	
Modulation input signals	Analog: 0...5V -> 0...100% Digital: 0...1V / 50 Ohm with programmable trigger-level	
Rise and fall time	< 1ns	
Extinction ratio	>250 : 1	
Supply voltage	85-245VAC, 50/60Hz	
Features	Safety-Interlock RS-232 interface	
Options	LDM.COL - collimator objective LDM.FOC - customized focussing objective LDM.FASYXXX - fibre coupling unit LDM.AAC - Automatic Aging Compensation LDM.MON - high-speed light monitoring	

BACK

MORE

LDM□□□□.□□□.TA  
Wavelength in nm Power in mW

LDM□□□□.□□□.DC180  
Wavelength in nm Power in mW

Deepstar® Controller

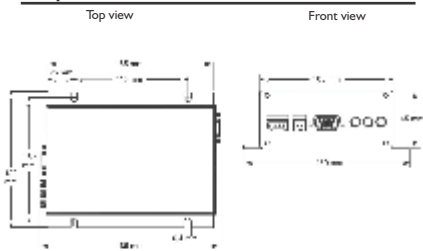

Deepstar® Laserhead

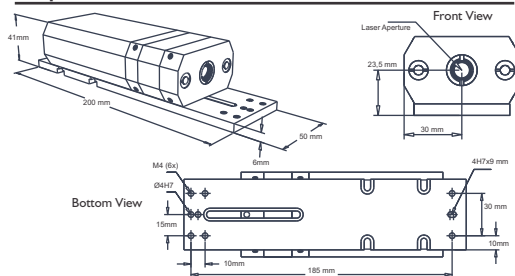

DC180 PSU

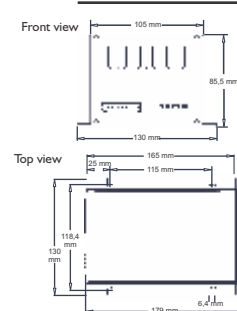

DC180 Controller

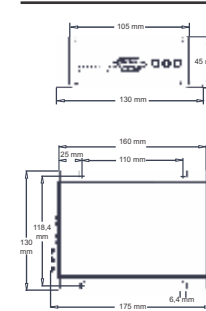

DC180 Laserhead

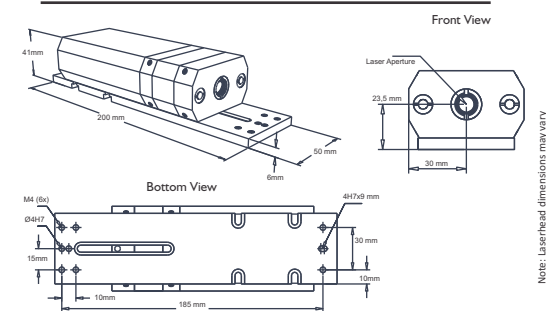

Note: Laserhead dimensions may vary

Note: Laserhead dimensions may vary

**PS350 - PulseShaping High Speed Modulated Diode Lasers with Programmable Pulse-Shaping**



**A350 - High Speed analogue modulated laser diode modules with up to 350MHz@-3dB**



**Blue-/Greenphoton® PS350 Redphoton® PS350**

Wavelengths & Powers (other wavelengths and powers on request)	<b>Single-Mode (SM):</b> 375nm / 20mW 395nm / 120mW 405nm / 55mW, 120mW 415nm / 120mW 425nm / 120mW 445nm / 50mW, 100mW 457nm / 100mW 460nm / 100mW 473nm / 20mW, 80mW 488nm / 20mW, 60mW, 80mW 515nm / 25mW <b>Multi-Mode (MM):</b> 375nm / 200mW (M <sup>2</sup> = 5...6) 405nm / 400mW (M <sup>2</sup> = 5...6) 445nm / 500mW (M <sup>2</sup> = 2...3)	<b>Single-Mode (SM):</b> 635nm / 5mW 637nm / 150mW 639nm / 40mW, 100mW 643nm / 150mW 658nm / 130mW 670nm / 15mW 685nm / 35mW 785nm / 120mW 808nm / 200mW 830nm / 200mW 852nm / 150mW 980nm / 150mW 1016nm / 100mW 1060nm / 100mW <b>Multi-Mode (MM):</b> 638nm / 250mW (others on request)
Beam diameter (other diameters on request)	1.25mm (1/e <sup>2</sup> ) +/- 0.25mm 3 mm (1/e <sup>2</sup> ) +/- 0.3mm	1.25mm (1/e <sup>2</sup> ) +/- 0.25mm 3 mm (1/e <sup>2</sup> ) +/- 0.3mm
Beam quality M <sup>2</sup>	< 1.2 (SM) < 6 (MM)	< 1.2 (SM) < 6 (MM)
Astigmatism (corrected)	< 0.2*ZR	< 0.2*ZR
Beam ellipticity	< 1.1:1 (SM)	< 1.1:1 (SM)
Polarisation	> 100:1 vertical	> 100:1 vertical
Power stability	< 0.5% / h	< 0.5% / h
Noise 0Hz-100MHz	< 0.5% peak <-> peak (CW)	< 0.5% peak <-> peak (CW)
Modulation speed	Analogue: peak power control with 1.5Hz bandwidth Digital: > 350MHz	
Modulation input signals	Analogue: 0...4V -> 0...100% peak power Digital: 0...1V / 50 Ohm with programmable trigger-level	
Rise and fall time	< 1ns	
Extinction ratio	> 250 : 1	
Pulse shaping parameter	Programmable burst height 0...100% of peak power Programmable burst length 5.5ns -500ns	
Supply voltage	85-245VAC, 50/60Hz	
Features	Safety-Interlock RS-232 interface	
Options	LDM.COL - collimator objective LDM.FOC - customized focussing objective LDM.FASY:XXX - fibre coupling unit LDM.AAC - Automatic Aging Compensation LDM.MON - high-speed light monitoring	

**Blue-/Greenphoton® A350 Redphoton® A350**

Wavelengths & Powers (other wavelengths and powers on request)	<b>Single-Mode (SM):</b> 375nm / 20mW 395nm / 120mW 405nm / 55mW, 120mW 415nm / 120mW 425nm / 120mW 445nm / 50mW, 100mW 457nm / 100mW 460nm / 100mW 473nm / 20mW, 80mW 488nm / 20mW, 60mW, 80mW 515nm / 25mW <b>Multi-Mode (MM):</b> 375nm / 200mW (M <sup>2</sup> = 5...6) 405nm / 400mW (M <sup>2</sup> = 5...6) 445nm / 500mW (M <sup>2</sup> = 2...3)	<b>Single-Mode (SM):</b> 635nm / 5mW 637nm / 150mW 639nm / 40mW, 100mW 643nm / 150mW 658nm / 130mW 670nm / 15mW 685nm / 35mW 785nm / 120mW 808nm / 200mW 830nm / 200mW 852nm / 150mW 980nm / 150mW 1016nm / 100mW 1060nm / 100mW <b>Multi-Mode (MM):</b> 638nm / 250mW (others on request)
Beam diameter (other diameters on request)	1.25mm (1/e <sup>2</sup> ) +/- 0.25mm 3 mm (1/e <sup>2</sup> ) +/- 0.3mm	1.25mm (1/e <sup>2</sup> ) +/- 0.25mm 3 mm (1/e <sup>2</sup> ) +/- 0.3mm
Beam quality M <sup>2</sup>	< 1.2 (SM) < 6 (MM)	< 1.2 (SM) < 6 (MM)
Astigmatism (corrected)	< 0.2*ZR	< 0.2*ZR
Beam ellipticity	< 1.1:1 (SM)	< 1.1:1 (SM)
Polarisation	> 100:1 vertical	> 100:1 vertical
Power stability	< 0.5% / h	< 0.5% / h
Noise 0Hz-100MHz	< 0.5% peak <-> peak (CW)	< 0.5% peak <-> peak (CW)
Modulation speed	Analogue: up to 350MHz @ -3dB Digital: > 350MHz	
Modulation input signals	Analogue: 0...1V / 50 Ohm Digital: 0...1V / 50 Ohm with programmable trigger-level peak power control: 0...4V -> 0...100% with 1.5Hz bandwidth	
Rise and fall time	Analogue: < 2ns Digital: < 1ns	
Extinction ratio	> 250 : 1	
Supply voltage	85-245VAC, 50/60Hz	
Features	Safety-Interlock RS-232 interface	
Options	LDM.COL - collimator objective LDM.FOC - customized focussing objective LDM.FASY:XXX - fibre coupling unit LDM.AAC - Automatic Aging Compensation LDM.MON - high-speed light monitoring	

BACK

LDM□□□□ . □□□ . PS350  
Wavelength in nm Power in mW

LDM□□□□ . □□□ . A350  
Wavelength in nm Power in mW

**PS350 / A350 Laserhead**

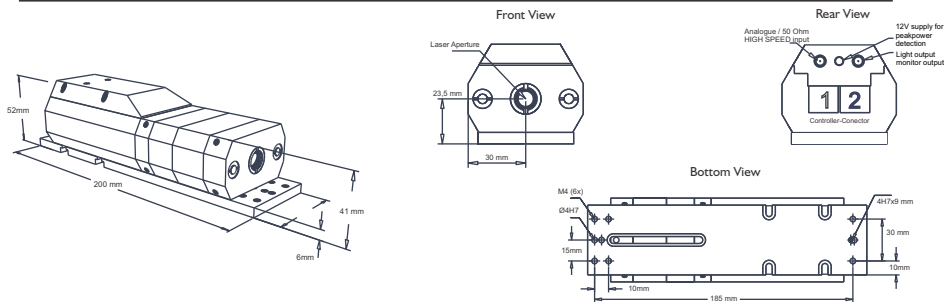

**PS350 / A350 PSU**

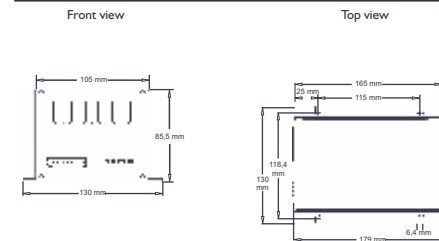

**PS350 / A350 Controller**

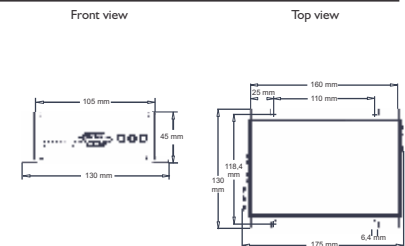

Note: Laserhead dimensions may vary

Note: Laserhead dimensions may vary