

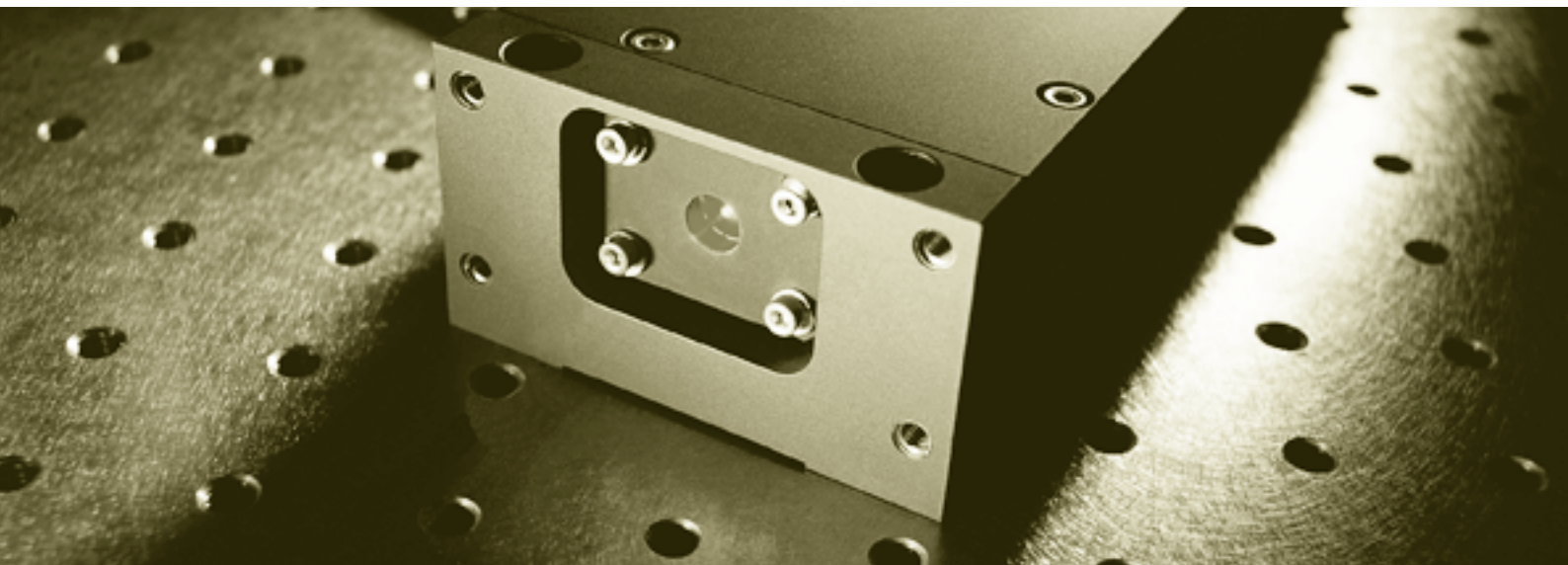

## JenLas<sup>®</sup> D2.IR

Diode-Pumped Thin-Disk Laser



### Features:

- OEM design for easy integration
- Peltier cooling (TEC), system contains no water
- High beam quality
- Small dimensions
- Long Life Performance

### Technology:

- Thin-disk laser
- Diode pumping
- cw operation

### Applications:

- Micro material processing
- Medical engineering

Excellence through light: Lasers

# JenLas<sup>®</sup> D2.IR

## Diode-Pumped Thin-Disk Laser

### Specifications

#### Parameters

Laser	Thin-disk laser, diode-pumped
Laser class	4 (according to EN 60825-1)
Wavelength	1064 nm
Ambient temperature	5 °C ... 40 °C

#### cw operation

Output power	8 W
M <sup>2</sup> (typical)	5 (coupling into fiber with 50 µm core)
Pulse duration, switchable via diode laser current	~ 1 ms to cw
Beam diameter	< 2 mm

#### Electrical specifications

Electrical input data	2 V, typically 23 A (at diode laser)
Input power	≤ 60 VA

#### Mechanical specifications

Dimensions (W x H x L)	70 mm x 40 mm x 200 mm
Weight	1.8 kg

For the operation of the laser, a suitable power supply must be used that complies with the regulations relevant to the respective application. Please contact us for further technical details.

#### Laser head

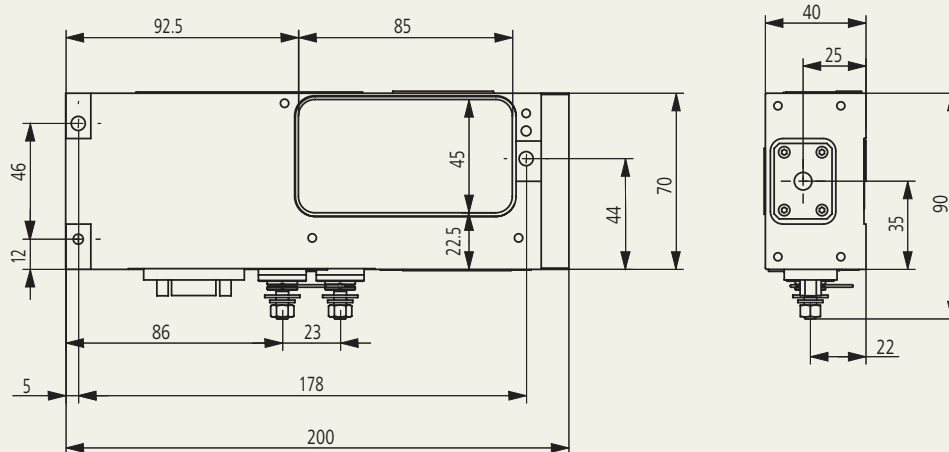

It is our policy to constantly improve the design and specifications. Accordingly, the details represented herein cannot be regarded as final and binding.



JENOPTIK Laser, Optik, Systeme GmbH  
Business Unit Laser Systems  
Goeschwitzer Strasse 25, 07745 Jena, Germany  
Phone +49 3641 65-2548 Fax +49 3641 65-3117  
E-mail: laser.sales@jenoptik.com  
Internet: www.jenoptik-los.com

