

RIDGE WAVEGUIDE LASER with AR-COATING

GaAs Semiconductor Laser Diode

Tunable Fabry-Perot Laser for External Cavity Operation

**PRELIMINARY SPECIFICATION****RWE Laser****EYP-RWE-0790-04000-0750-SOT01-0000****General Product Information**

Product	Application
tunable 790 nm Fabry-Perot Laser	Spectroscopy
for use in an External Cavity Diode Laser (ECDL)	
sealed SOT Housing	
Monitor Diode	

Absolute Maximum Ratings

	Symbol	Unit	min	typ	max
Storage Temperature	T_S	°C	-20		85
Operational Temperature at Case	T_C	°C	-20		50
Forward Current	I_F	mA			200
Reverse Voltage	V_R	V			0
Output Power (extracavity)	P_{opt}	mW			100

Recommended Operational Conditions

	Symbol	Unit	min	typ	max
Operational Temperature at case	T_C	°C	15		40
Forward Current	I_F	mA			180

Characteristics at T_{amb} 25 °C at Begin Of Life

Parameter	Symbol	Unit	min	typ	max
Center Wavelength	λ_c	nm		770	
Tuning Range	$\Delta\lambda_{tun}$	nm	750		790
Output Power (extracavity)	P_{opt}	mW		50	
Cavity Length	L	μm		750	
Reflectivity at Front Facet	R_{ff}			$3 \cdot 10^{-4}$	$1 \cdot 10^{-3}$
Polarization				TM	

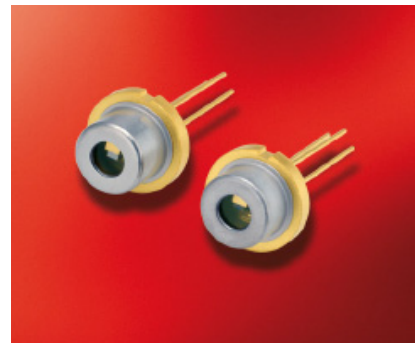

Stress in excess of the Absolute Maximum Ratings can cause permanent damage to the device. Operation at the Absolute Maximum Rating for extended periods of time can adversely affect the device reliability and may lead to reduced operational life.

Measurement Conditions / Comments

Tuning range and output power are estimated from the gain profile of the laser. The actual achieved wavelength and power are strongly influenced by the external cavity. Therefore eagleyard Photonics will give no guarantee on these parameters.

Polarization perpendicular to Pin 2 - Pin 3 -plane

RIDGE WAVEGUIDE LASER with AR-COATING

GaAs Semiconductor Laser Diode

Tunable Fabry-Perot Laser for External Cavity Operation



RWE/RWL



BAL



DFB/DBR



TPL/TPA

PRELIMINARY SPECIFICATION**RWE Laser****EYP-RWE-0790-04000-0750-SOT01-0000****Monitor Diode**

Parameter	Symbol	Unit	min	typ	max
Monitor Detector Responsivity	$I_{\text{mon}} / P_{\text{opt.ic}}$	$\mu\text{A} / \text{mW}$	1		10
Reverse Voltage Monitor Diode	$U_{\text{R.MD}}$	V	3		5

Measurement Conditions / Comments $U_{\text{R.MD}} = 5 \text{ V}$, $P_{\text{opt.ic}}$: intracavity power of the ECDL

RIDGE WAVEGUIDE LASER with AR-COATING

GaAs Semiconductor Laser Diode

Tunable Fabry-Perot Laser for External Cavity Operation

**PRELIMINARY SPECIFICATION****EYP-RWE-0790-04000-0750-SOT01-0000****Package Dimensions**

	Symbol	Unit	min	typ	max
Emission Plane	d_{EP}	mm	2.30	2.45	2.50
Housing Diameter	d	mm		9.0	
Pin Length	l	mm		14.0	

Package Pinout**M-Type**

Ground	1
Photo Diode (+)	2
Laser (+)	3

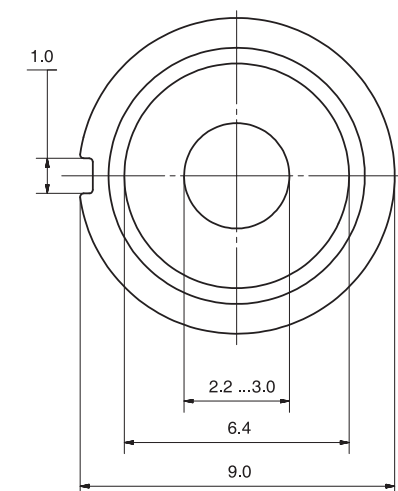
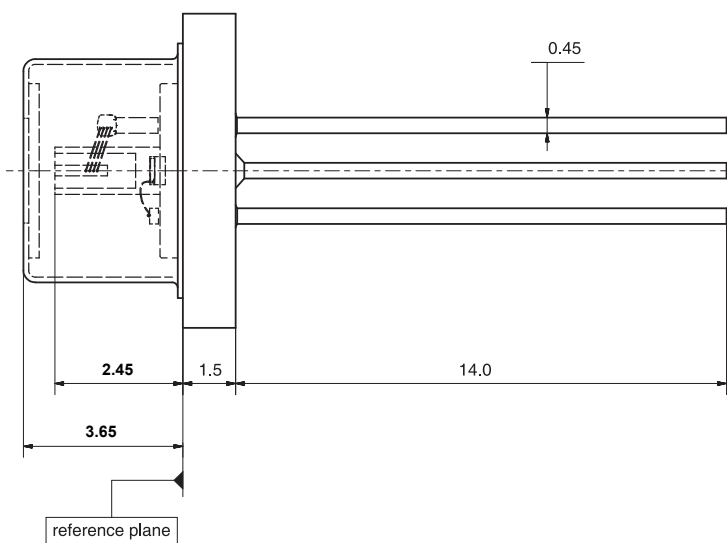
Package Drawings**RWE Laser**

reference plane: top side of TO header

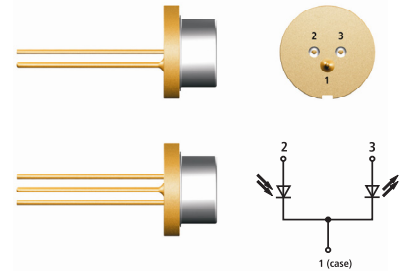

RIDGE WAVEGUIDE LASER with AR-COATING

GaAs Semiconductor Laser Diode
Tunable Fabry-Perot Laser for External Cavity Operation



PRELIMINARY SPECIFICATION

EYP-RWE-0790-04000-0750-SOT01-0000

Typical Measurement Results

Emission Spectrum measured without external feedback

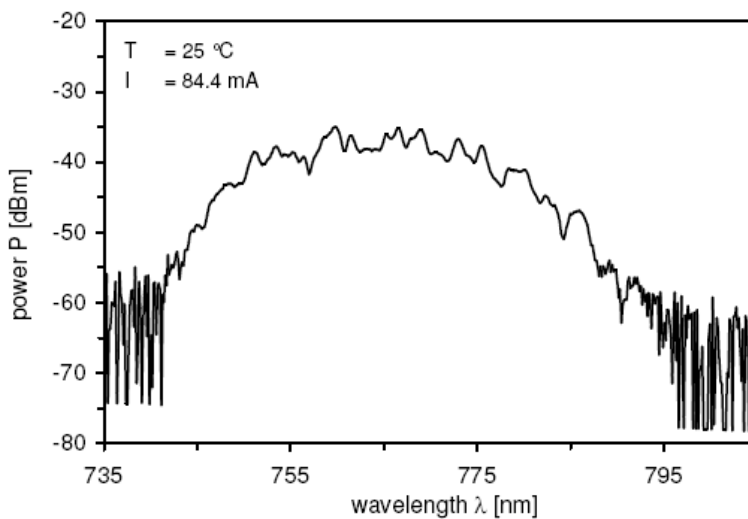

Unpacking, Installation and Laser Safety

Unpacking the laser diodes should only be done at electrostatic safe workstations (EPA). Though protection against electro static discharge (ESD) is implemented in the laser package, charges may occur at surfaces. Please store this product in its original package at a dry, clean place until final use. During device installation, ESD protection has to be maintained.

The RWE diode type is known to be sensitive against thermal stress. It should not be operated without appropriate optical feedback from an external cavity. Operating at moderate temperatures on proper heat sinks will contribute to a long lifetime of the diode.

The laser emission from this diode is close to the invisible infrared region of the electromagnetic spectrum. Avoid direct and/or indirect exposure to the free running beam. Collimating the free running beam with optics as common in optical instruments will increase threat to the human eye.

Each laser diode will come with an individual test protocol verifying the parameters given in this document.



RWE Laser

Performance figures, data and any illustrative material provided in this specification are typical and must be specifically confirmed in writing by eagleyard Photonics before they become applicable to any particular order or contract. In accordance with the eagleyard Photonics policy of continuous improvement specifications may change without notice.

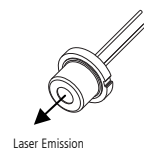

Complies with 21 CFR 1040.10 and 1040.40